

# Electric Motors and Generators

---

Motors run a tremendous number of devices, from toy trains to refrigerators, from air conditions to cars. What is inside a motor and how do they work? How are motors related to electric generators? Those are the questions that we will investigate in today's lab.

## Activity 1: Building the simplest electric motor

### Steps to building the motor

-Use the two rubber band to attach the bare copper wires to the plastic cup

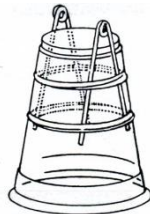

-Clamp an alligator clip to one end of each of the bare copper wires

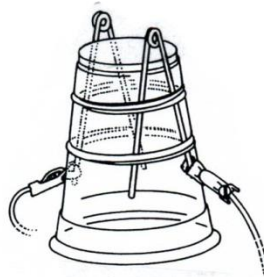

-Hook up the rest of the circuit by connecting the battery and the switch to the alligator clips with three pieces of wire as shown.

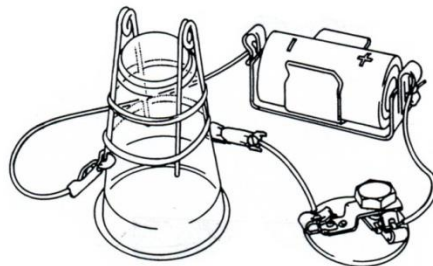

-Bend the ends of the coil of wire so that they stick straight out on opposite sides of the coil



-Next place the ends of the coil through the loops in the bare wire on each side of the cup. If necessary, bend the coil and/or adjust the loops so that the coil can spin freely without hitting anything or wobbling too much.

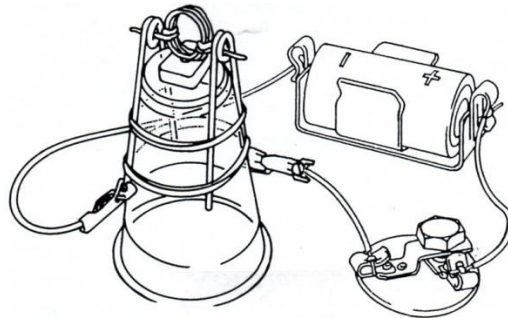

-Place a magnet on the top of the inverted cup, underneath the coil or hold it and move it around the coil. Turn the switch on and blow gently on the coil to help it get started. If the coil will not spin continuously, try putting the magnet somewhere else, turning it over or bending the support wires or wires on the coil so that the coil spins more smoothly.

1. Take a sheet of paper that you will use for your lab write-up. Put your name on the top. Have your teacher initial #1 to confirm that your motor works.
2. Is the coil an electromagnet? How do you know? That is, what evidence do you have?
3. What force makes the coil spin? The magnetic force? The electric force? Something else? Explain your reasoning.

## Exercise 2: Parts of a small electric motor

-Hook the small electric motor (with the wires attached) to a battery and make sure that you can make the motor run.

4. Can you make the motor turn in the opposite direction? If so, how? You can put a small piece of a straw on the end of the motor to make it easier to see the motor turning.
5. What type of energy is input to the motor? What type of energy is output from the motor?

-Now you are going to take the motor apart. Begin by bending the metal tabs away from the plastic at the end of the motor as shown below. You can use a nail to do this if that helps. Once you bend the tabs out of the way, push on the axel of the motor to open it up.

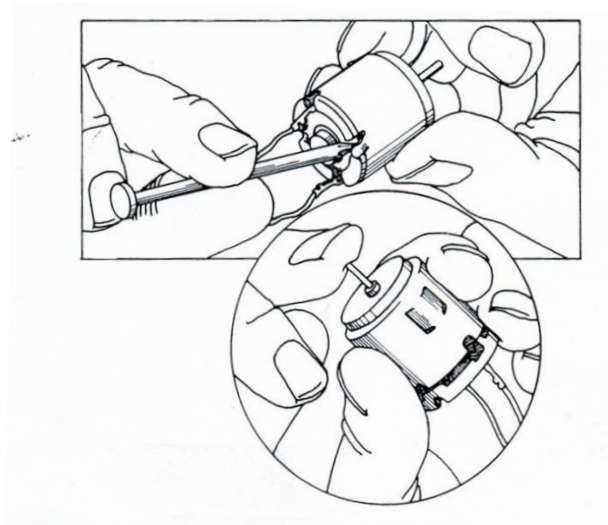

The motor cap should come off as shown. Next, separate the motor into three pieces by taking out the spinning coils.



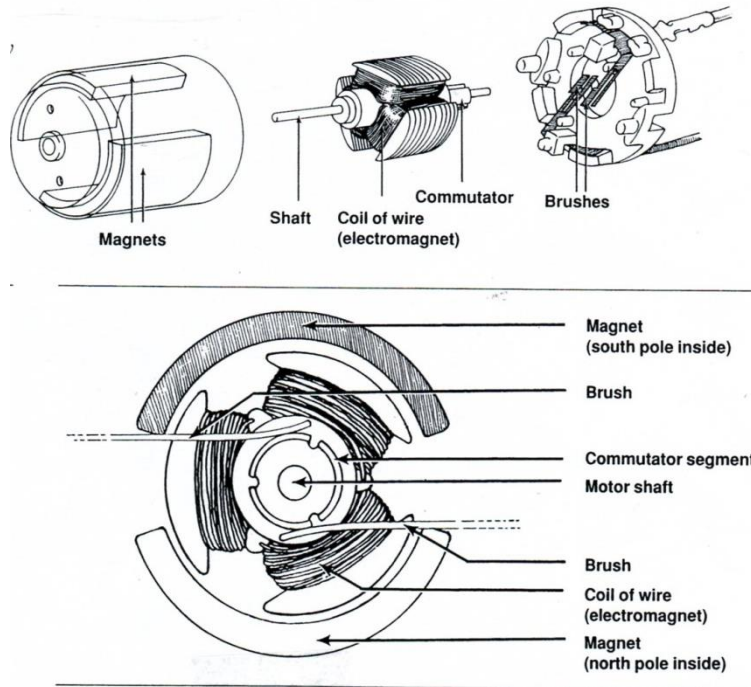

6. Look at all of the many parts that make up the motor. Think about the simple (spinning coil) motor you just built and compare it to this motor. Think about what the parts of each motor do. List pairs of parts that serve the same purpose. One part in the pair should be from the spinning coil motor you made and one part in the pair should be from this motor.

7. All of the parts of the motor help in some way to make the motor run. For each part shown in the figure above, write a complete sentence that uses the name of the part and states what part it plays in making the motor work. If you can't figure out what the part does, ask your teacher.

8. Suppose that a friend asks you to explain the physics behind an electric motor. In a few complete and clear sentences answer your friend.

### Activity 3: Making an armature spin

-Replace pieces on your plastic cup so that it looks like that shown below. Move the bare cooper wire so that the loop is directly above the center of the cup.

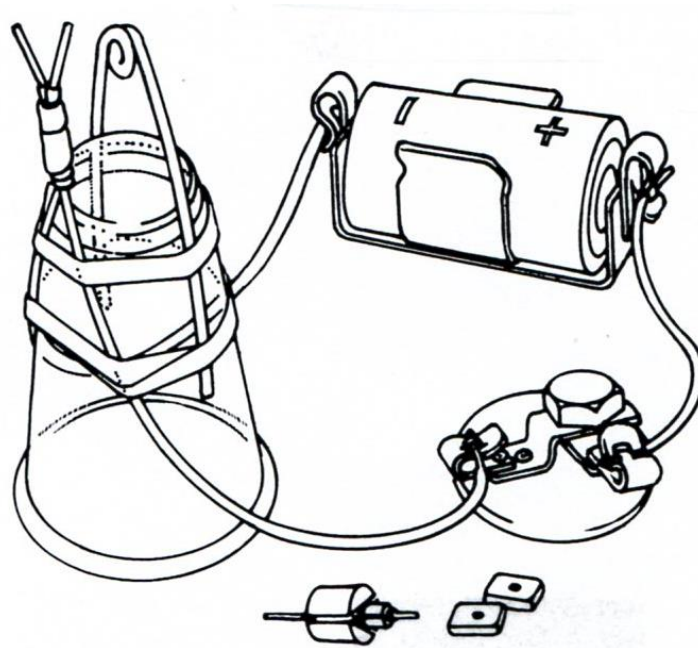

-Place the armature of the motor you took apart on the test stand. Bend the wires so that the armature fits and will not fall off.

9. Which end of the armature needs to rest in the V? The end with the commutator or the end without the commutation? Explain **how** you figured this out. Explain **why** that is the end of the armature that must be in the V?

-Connect the circuit so that current flows through the circuit. Hold a magnet near the armature. Keep trying until you can make the armature spin. This might require changing the position of the magnet or adjusting the position of the armature in the V.

10. Experiment with two magnets to find the location that makes the motor spin the fastest. Does it matter how close the magnets are to the armature? What can you do to make the motor slow down?

11. Experiment to find ways to make the motor change direction. How many ways can you find? What are they?

12. Put the motor back together. (See below for hints.) Have your teacher initial your lab sheet to confirm that you were successful in rebuilding the motor and that it still works.

#### Activity 4: Electric Generators are Just Electric Motors Run Backward

Place a rubber band over the box provided. Position the rubber band right at the edge along the shorter side. Attach the motor to a light bulb forming a closed loop. Quickly spin the shaft of the motor by running the shaft along the rubber band. YOU SHOULD BE ABLE TO MAKE THE BULB LIGHT. **The electric motor is now operating as an electric generator.**

13. Have your teacher initial your lab sheet to confirm that you got the bulb to light.

Electric generators that are fundamentally just like our little electric motor/generator are the basic component in all large electricity generating facilities. The key difference between wind generated electricity, hydroelectric and nuclear, natural gas or coal fired power plants is simply what energy source is used to make the shaft of the generator rotate. In wind farms, wind directly turns blades attached to the shaft of the generator. In hydroelectric plants, the shaft is rotated when falling water passes through a device called a **turbine** (see the figure below) which is basically a sophisticated water wheel. Nuclear, coal and natural gas fired power plants use those fuels to heat water. The steam produced flows through the turbine which turns the generator shaft. (Electricity generated using solar energy is produced using entirely different physics.)

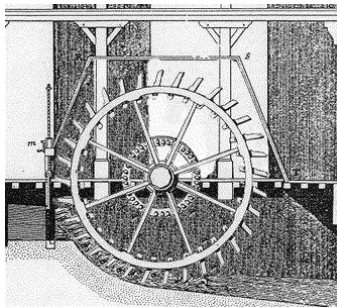
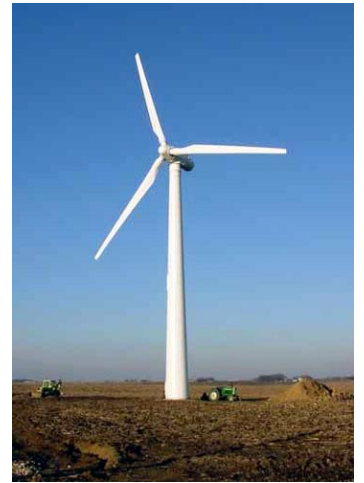

A very basic turbine (water wheel) using falling water to turn the shaft of an electric generator.

14. What type of energy is input to an electric generator? What type of energy is output from an electric generator?

15. In what ways, if any, is an electric motor different from an electric generator in regard to their basic design and key components?

16. The subtitle of this section is “Electric Generators are Just Electric Motors Run Backward”. Given your answers to #14 and #15 above would you agree? Explain.

17. Describe what you need to do to generate electricity using only wire and a magnet.